

J-J

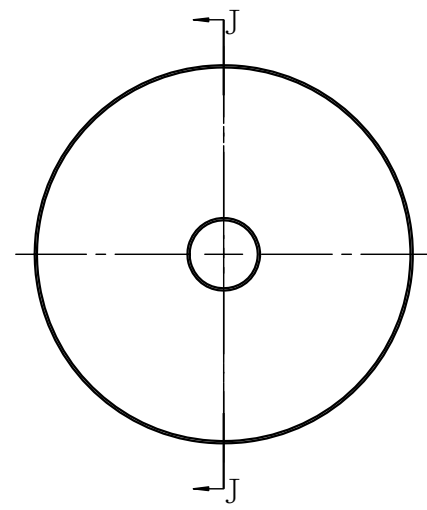

DIMENSIONS ARE IN mm TOLERANCES FRACTIONAL ± ANGULAR: MACH ± BEND ± ONE PLACE DECIMAL ± TWO PLACE DECIMAL ±		NAME	DATE	Richelieu Hardware		
	DRAWN					RICHELIEU /VENDOR ITEM NUMBER 246TY900433060
	CHECKED					
	ENG APPR.					
	MFG APPR.					
	Q.A.			SIZE	DWG.NO.	REV.
MATERIAL: Steel	COMMENTS:		1	A	Washer	0
FINISH: Electroplate				DO NOT SCALE DRAWING		SHEET 1OF 1
WEIGHT(GR): 88.78						